

NON THROUGH-HOLE ROTARY HYDRAULIC CYLINDER

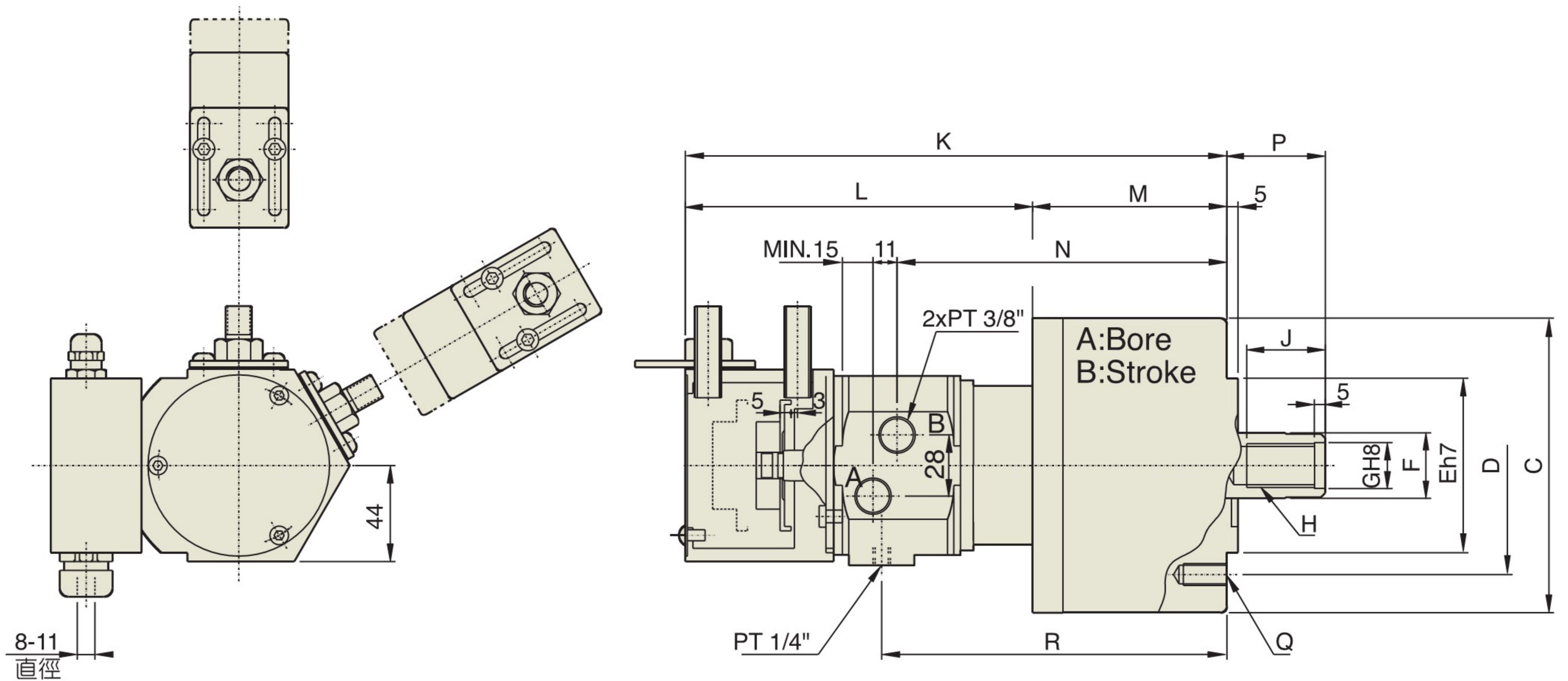

- 內附逆止閥。
- 檢知確認裝置。
- Built-in safety check valves.



規格 SPECIFICATIONS

型式 MODEL	活塞行程 Piston Stroke (mm)	活塞面積 Effective Piston Area		最大拉桿推力 Max.Draw Bar Pull <拉側 Pull side> KN(kgf)	最高使用油壓力 Max. Operating Pressure MPa <拉側 Pull side> (kgf/cm ²)	總流量 Total Leakage (l/min)	最高轉速 Max. Speed (r.p.m.)	重量 Weight (kg)	慣性矩 Moment of Inertia (kgf.m ²)
		推側 Push Side (cm ²)	拉側 Pull Side (cm ²)						
MS105C	20	84	79	29(2957)	4.0(40.8)	0.8	6,000	7.6	0.0125
MS125C	25	120	113	42(4283)	4.0(40.8)	0.8	6,000	10.5	0.022
MS150C	30	174	160	60(6118)	4.0(40.8)	0.8	5,500	14	0.047
MS200C	35	312	290	108(11013)	4.0(40.8)	0.8	5,500	22.5	0.097

尺寸表 DIMENSIONS

型式 MODEL	A	B	C	D	E	F	G	H	J	K	L	M	N	P Max	P Min	Q	R	S	T
MS105C	105	20	135	100	80	30	21	M20X2.5	35	252	163	89	152	45	25	6-M10X20	158	23	41
MS125C	125	25	160	130	110	35	25	M24X3.0	44	260	163	97	160	51	26	6-M12X24	166	23	41
MS150C	150	30	190	130	110	45	31	M30X3.5	45	269	163	106	169	56	26	12-M12X24	175	23	41
MS200C	200	35	245	145	120	55	37	M36X4.0	60	288	166	122	185	69	34	12-M16X30	189	28	46

- 拉桿推力：油壓力 4.0MPa(40.8 kg/cm²)
- 總流量：油壓力 3.0MPa(30.6 kg/cm²) 及溫度 50 °C
- 近接開關：規格 BES516-329-E4-Y(BALLUFF) DC 12/24V 200mA NPN
- Draw bar pull force:Pressure 4.0MPa(40.8 kg/cm²)
- Total leakage :Pressure 3.0MPa(30.6 kg/cm²)and oil temperture 50 °C
- Proximity switch:Model BES516-329-E4-Y9BALLUFF) DC12/24V 200mA NPN